

Models: KCE 140PA    KCE 180PD

## **WARNING**

**TO REDUCE THE RISK OF FIRE, ELECTRIC SHOCK, OR INJURY TO PERSONS, OBSERVE THE FOLLOWING:**

1. Use this unit only in the manner intended by the manufacturer. If you have questions, contact the manufacturer at the address or telephone number listed in the warranty.
2. Before servicing or cleaning unit, switch power off at service panel and lock the service disconnecting means to prevent power from being switched on accidentally. When the service disconnecting means cannot be locked, securely fasten a prominent warning device, such as a tag, to the service panel.
3. Installation work and electrical wiring must be done by a qualified person(s) in accordance with all applicable codes and standards, including fire-rated construction codes and standards.
4. Sufficient air is needed for proper combustion and exhausting of gases through the flue (chimney) of fuel burning equipment to prevent backdrafting. Follow the heating equipment manufacturer's guideline and safety standards such as those published by the National Fire Protection Association (NFPA), and the American Society for Heating, Refrigeration and Air Conditioning Engineers (ASHRAE), and the local code authorities.
5. When cutting or drilling into wall or ceiling, do not damage electrical wiring and other hidden utilities.
6. Ducted fans must always be vented to the outdoors.
7. Acceptable for use over a tub or shower when connected to a GFCI (Ground Fault Circuit Interrupter) - protected branch circuit (ceiling installation only).
8. This unit must be grounded.

## **CAUTION**

1. For general ventilating use only. Do not use to exhaust hazardous or explosive materials and vapors.
2. This product is designed for installation in ceilings up to a 12/12 pitch (45 degree angle). Duct connector must point up. **DO NOT MOUNT THIS PRODUCT IN A WALL.**
3. To avoid motor bearing damage and noisy and/or unbalanced impellers, keep drywall spray, construction dust, etc. off power unit.
4. Please read specification label on product for further information and requirements.

## **CLEANING & MAINTENANCE**

For quiet and efficient operation, long life, and attractive appearance - lower or remove grille and vacuum interior of unit with the dusting brush attachment.

The motor is permanently lubricated and never needs oiling. If the motor bearings are making excessive or unusual noises, replace the motor with the exact service motor. The impeller should also be replaced.

## **OPERATION**

See "CONNECT ELECTRICAL WIRING" for details.

**READ AND SAVE THESE INSTRUCTIONS**  
Installer: Leave this manual with the homeowner.

## PLAN THE INSTALLATION

1. Do not use in a cooking area.
2. Two ways to connect ductwork to a factory-shipped unit.

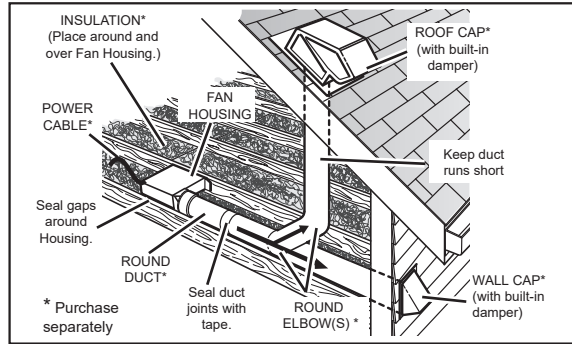
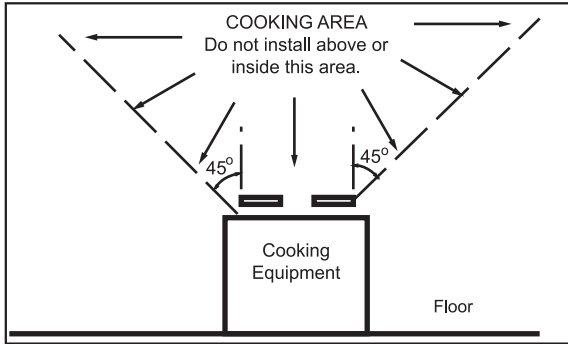

## TYPES OF TYPICAL INSTALLATIONS

1. Housing mounted to I-joists (Start at "ASSEMBLY INSTRUCTIONS 1")
2. Housing mounted to joists (Start at "ASSEMBLY INSTRUCTIONS 1" )
3. Housing mounted to truss (Start at step "ASSEMBLY INSTRUCTIONS 2")

## ASSEMBLY INSTRUCTIONS

### 1. MOUNT HOUSING TO JOIST OR I-JOIST.

- a. Hold the housing so that it is in contact with the bottom of the joist.
- b. Attach the housing with four (4) screws to the joist through the holes in each mounting flange.

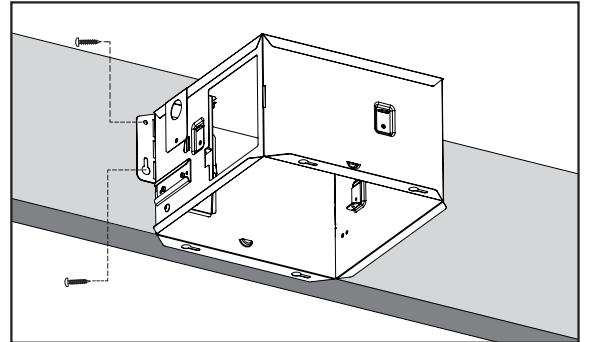

### 2. Mount with mounion holes and hanger bar

- a. Slide one hanger bar into the channel on the housing and adjust as needed to fit between framing.
- b. Hold housing in place so that the housing contact the bottom of the joist, Screw housing to joist through the hole of the housing .
- c. Screw the hanger bar onto the other side of joist through the hole.
- d. Screw hanger bar to housing with screw.
- e. Refer to the right diagram.

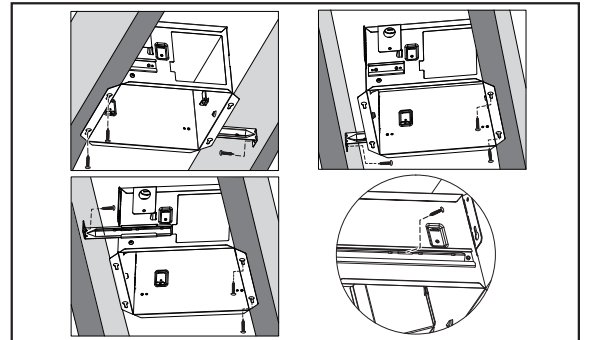

### 3. Mount to I-joist

- a. Slide one hanger bar into channel on the housing and adjust as needed.
- b. Hold housing in place so that the housing contacts the bottom of the joist.
- c. Screw housing to joist through the hole of the housing.
- d. Screw the hanger bar onto the joist through the hole.
- e. Screw hanger bar to housing with screw .

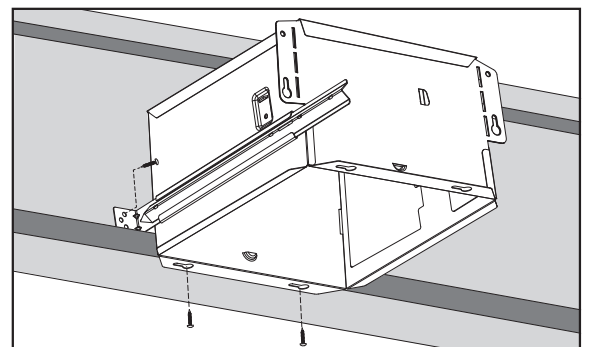

# ASSEMBLY INSTRUCTIONS

## 4. Install DUCT AND BLOWER ASSEMBLY

- a. Install duct from the inside of the housing; Fix the duct by the tab.
- b. Fix the BLOWER ASSEMBLY to the housing by 3 screws.

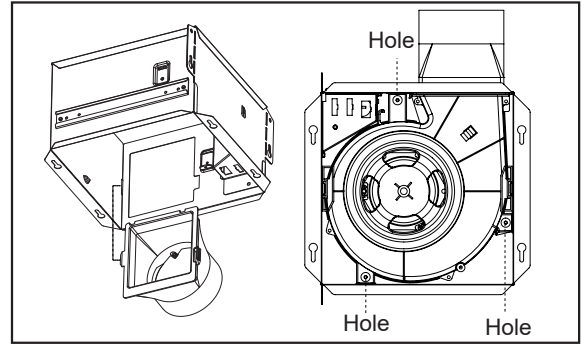

## 5. INSTALL ROUND DUCTWORK

- a. Connect the round ductwork (not included) to the damper/duct connector, and run the ductwork to a roof or wall cap (not included).
- b. Using tape (not included), secure all the ductwork connections so that they are air tight.
- c. Insulated flexible duct is recommended for the quietest possible installation. If rigid duct is used, a short (1-3 feet) section of insulated flexible duct will ensure quiet operation.

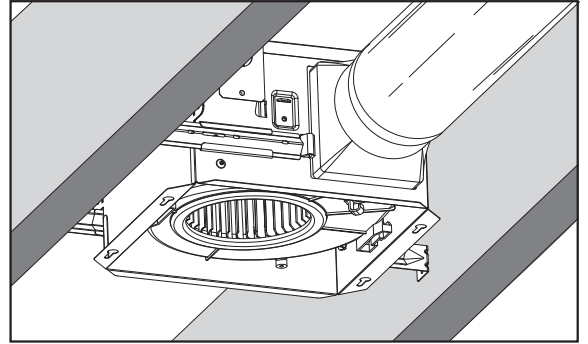

The ducting from this fan to the outside of building has a strong effect on the air flow, noise and energy use of the fan. Use the shortest, straightest duct routing possible for best performance, and avoid installing the fan with smaller ducts than recommended. Insulation around the ducts can reduce energy loss and inhibit mold growth. Fans installed with existing ducts may not achieve their rated air flow.

# RETROFIT INSTALLATION

1. Remove wire panel and blower assembly before installation.
2. Fold mounting ears flat against housing.

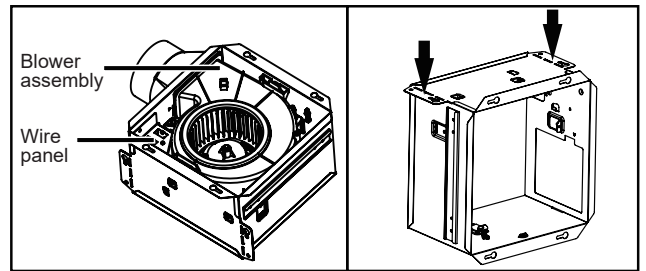

3. Enlarge ceiling opening to 9-1/2" by 9-1/2", leave ductwork and wiring in place.
4. Connect wiring according to the wiring diagram. Re-install wire panel.
5. Mounting fan
  - a. Mount with additional mounting holes  
The interior of the fan housing contains additional mounting holes in case exterior mounting is not possible.

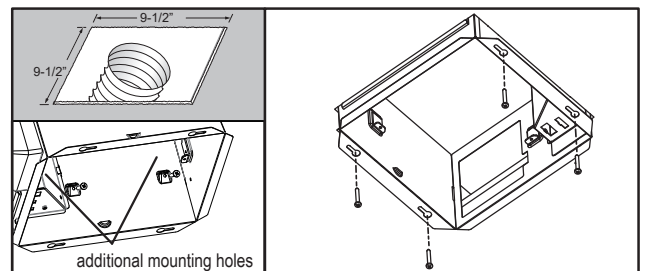

Screw or nail the fan housing directly to the framing or joists. Remove the blower assembly as directed in the service parts section of this manual to gain access to the additional mounting holes.

6. Mount with hole of the flange  
Use screws (included) to screw fans to the ceiling through the holes of the housing.
7. Connect duct  
Pull existing ducting through housing discharge opening and tape ducting to duct connector. Push connector/ducting back through opening, fix the duct by the tab.

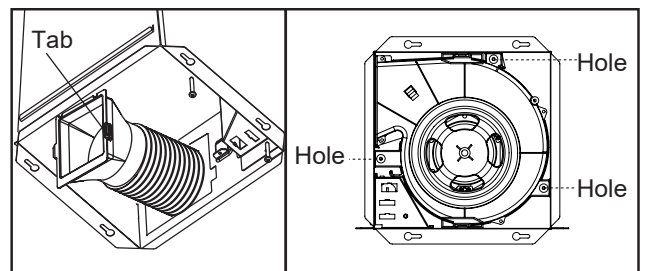

## CONNECT ELECTRICAL WIRING

Run 220V AC house wiring to the location of the fan. Use only UL-approved connectors (not included) to attach the house wiring to the wiring plate. Refer to the wiring diagram, and connect the wires as shown.

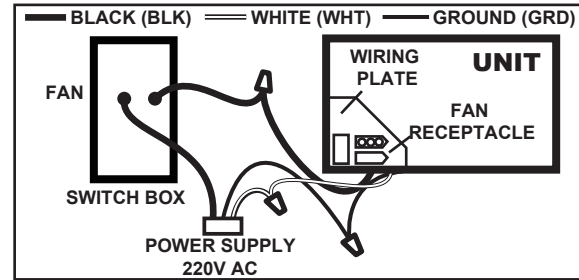
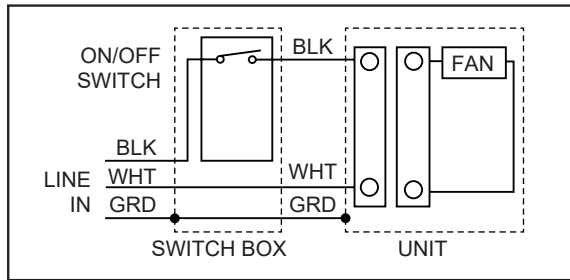

## INSTALL GRILLE

Install ceiling material to complete the ceiling construction and cut around the fan housing.

To attach the grille assembly to the fan housing, pinch the grille springs on the sides of the grille assembly and position the grille into the housing with the grille springs in the appropriate slots. Push the grille assembly towards the ceiling to secure.

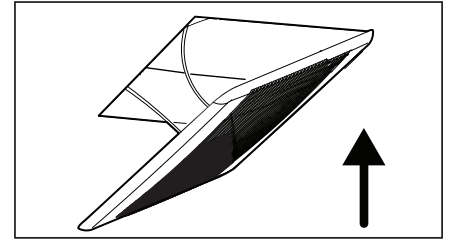

## SERVICE PARTS

PART	PART NAME	Qty.
1	Grille Assembly (includes part 2)	1
2	Grille Spring	2
3	Power Box (For KCE 140PD)	1
4	Blower	1
5	Blower Wheel	1
6	Motor	1
7	Motor Plate	1
8	Housing	1
9	Wire Panel / Harness Assembly	1
10	Hanger Bars	4
11	Wiring Plate	1
12	Damper/Duct Connector	1
a	Screw	3
b	Screw	3
c	Screw	4
d	Screw	2

\* Blower Assembly includes part 3, 4, 5, 6, 7, a, b

Replacement installation: Remove the screw (part a), then take out the blower assembly from the housing (part 8). Replace the broken parts.

**WARNING:** Ensure that the fan is switched off from the supply mains before replacing.

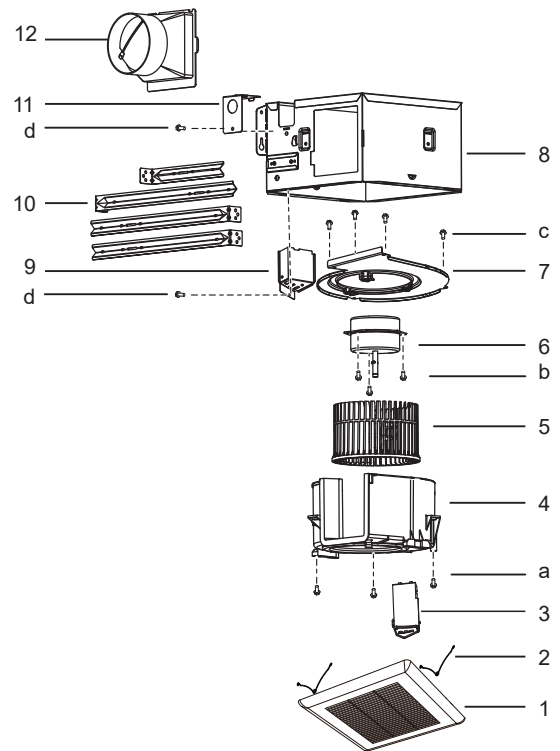

## WARRANTY

This warranty covers all defects in workmanship or materials for:

The mechanical and electrical parts contained in this product, for a period of 12 months, from the date of purchase. You must keep and be able to provide your original sales receipt as proof of the date of purchase. This warranty is covered the original retail purchaser of this product. The manufacturer will repair or replace, in your home, any mechanical or electrical part which proves defective in normal household use for a period of 12 months.

**THIS WARRANTY DOES NOT COVER:**

- Damages from improper installation
- Damages from shipping
- Damages from misuse, abuse, accident, alteration, lack of proper care and maintenance
- Damages from service by persons other than an authorized dealer or service center.
- Labor, service, transportation and shipping charges for the removal of defective parts and for installation of a replacement part, beyond the initial 12-month period.

This warranty does not extend to fluorescent lamp starters and tubes.

**THIS LIMITED WARRANTY IS GIVEN IN LIEU OF ALL OTHER WARRANTIES, EXPRESSED OR IMPLIED, INCLUDING THE WARRANTIES OF MERCHANTABILITY AND FITNESS FOR A PARTICULAR PURPOSE.**

The remedy provided in this warranty is exclusive and is granted in lieu of all other remedies. This warranty does not cover incidental or consequential damages. Some states do not allow the exclusion of incidental or consequential damages, so this limitation may not apply to you. Some states do not allow limitations on how long an implied warranty lasts, so this limitation may not apply to you. This warranty gives you specific legal rights, and you may also have other rights, which vary from state to state.